



# **QUICK CHANGE UNIVERSAL CLAMPING PALLET SYSTEM**

Easy quick and accurate  
positioning + clamping of each modular Gerardi fixture  
on every machine table.



# Art.33

Pneumatic chuck with flange and sensors for workpiece presence (option)





# Art.34 Hydraulic chuck with flange and sensors for workpiece presence (option)





2 Art.33 Pneumatic chucks + 1 Art.34 Hydraulic chuck in the center with sensors and positioning keys on head plate

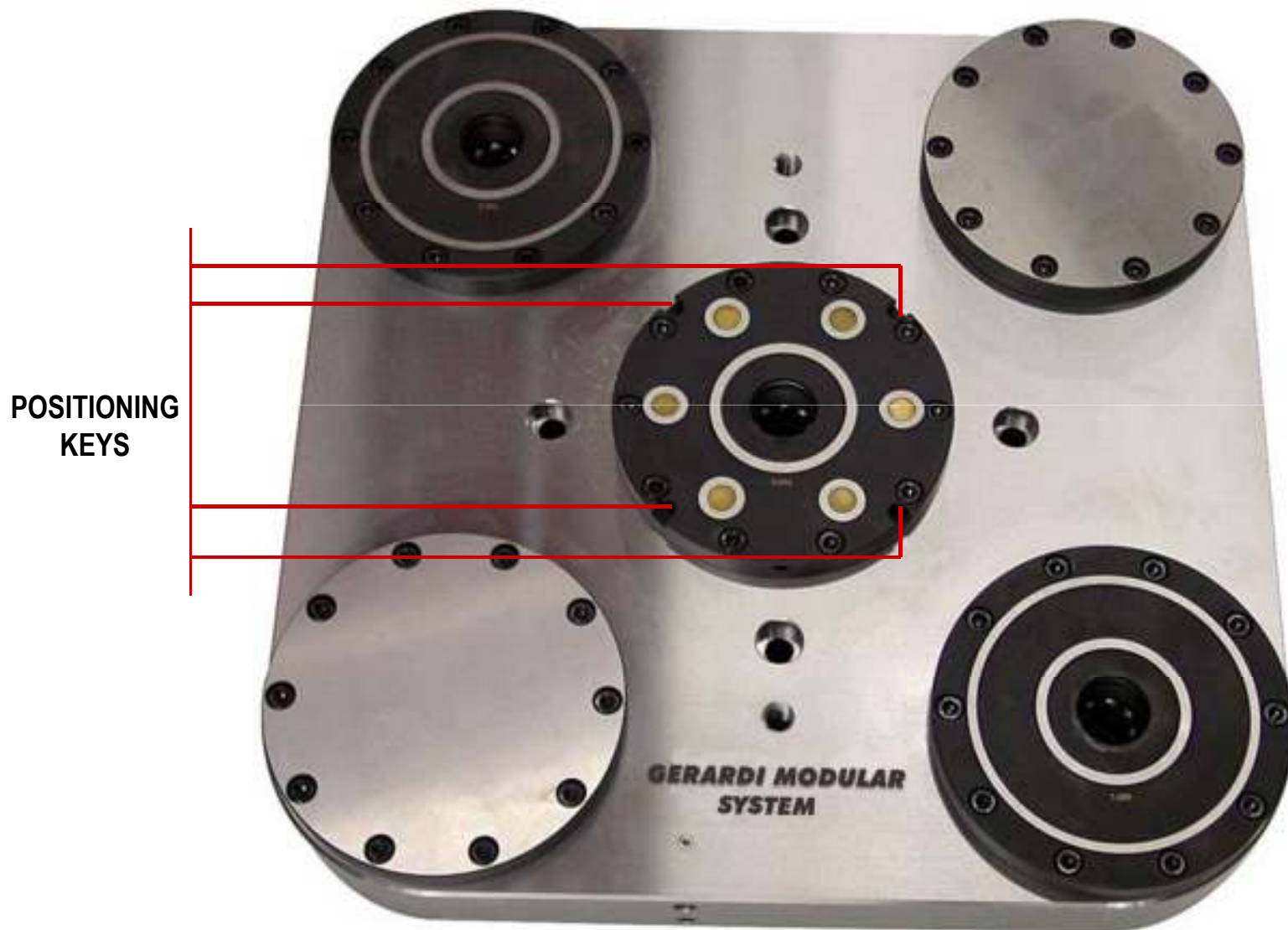

BUILT IN CONFIGURATION



Art.34 Hydraulic chucks. Central one with sensors and positioning keys



**BUILT IN  
CONFIGURATION**



# Art.34

Hydraulic chuck in the centre with sensors and positioning keys







# Art.34

Hydraulic chucks with flange

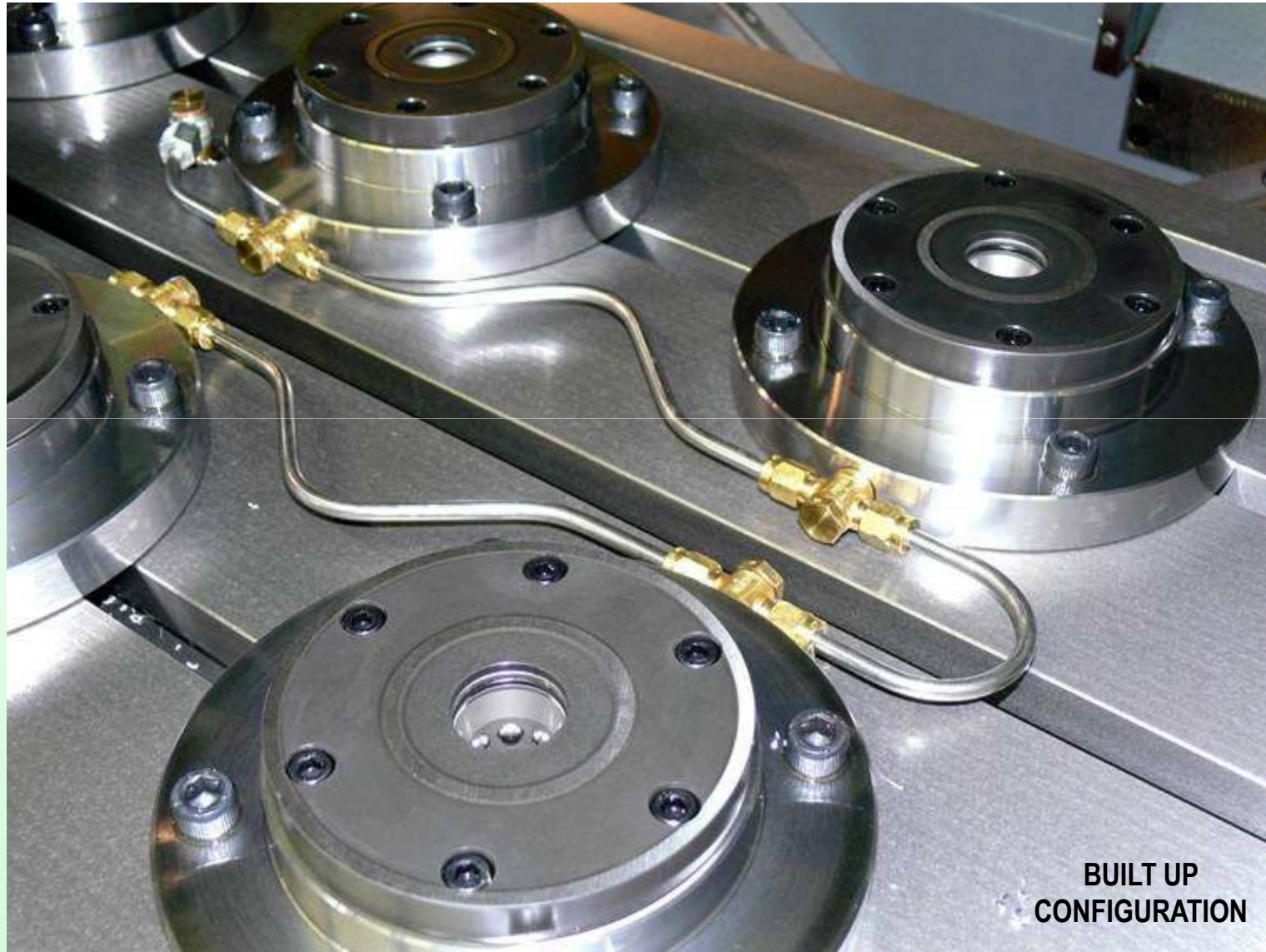

**BUILT UP  
CONFIGURATION**



## PNEUMATIC CHUCK

IDEAL FOR:

- Vertical use
- Operator

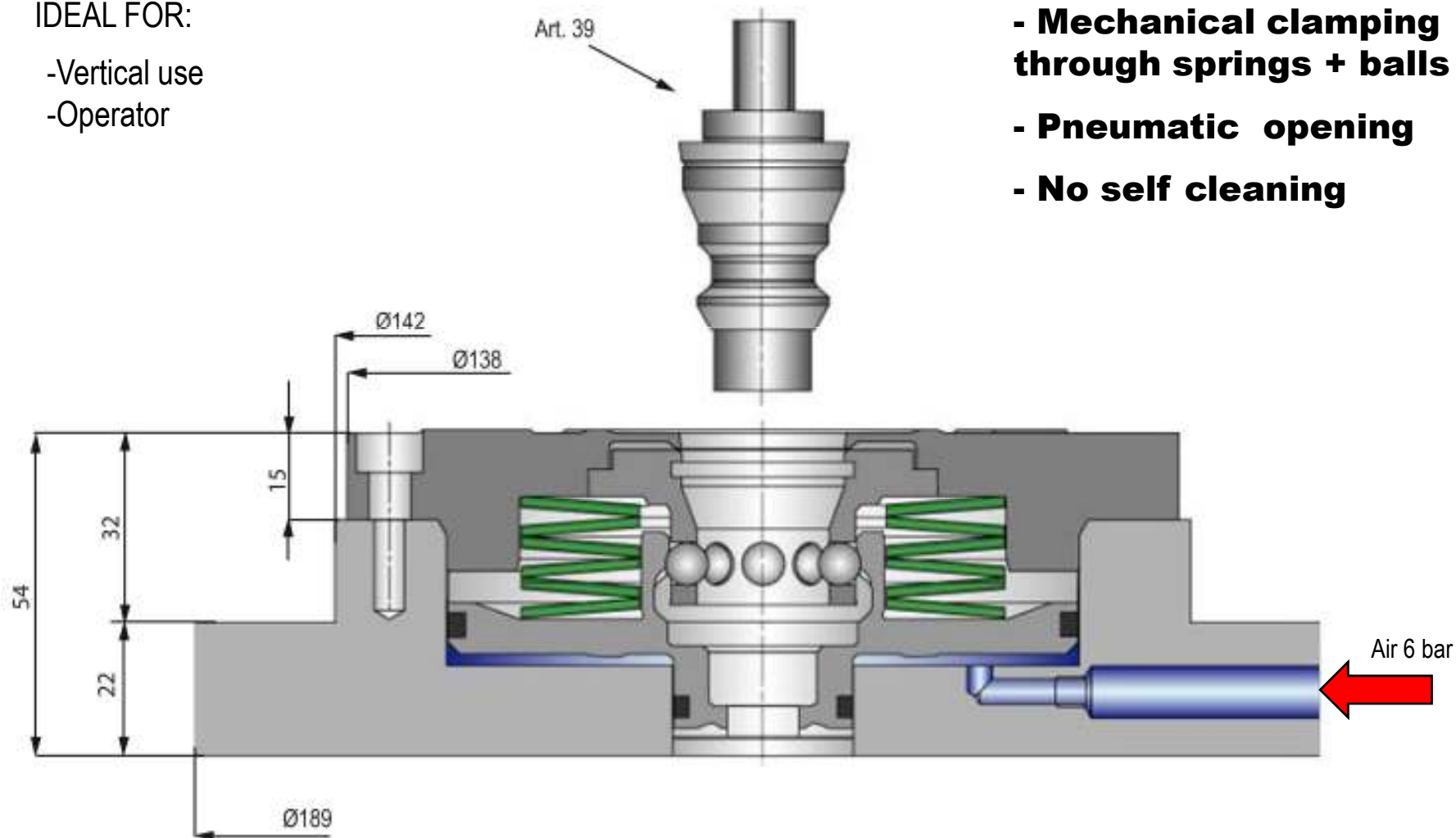



# Art.33

Pneumatic chuck with sensors for workpiece presence.

PNEUMATIC CHUCK  
IDEAL FOR:

- Vertical use
- No Operator

- **Mechanical clamping through springs + balls**
- **Pneumatic opening**
- **Self cleaning**

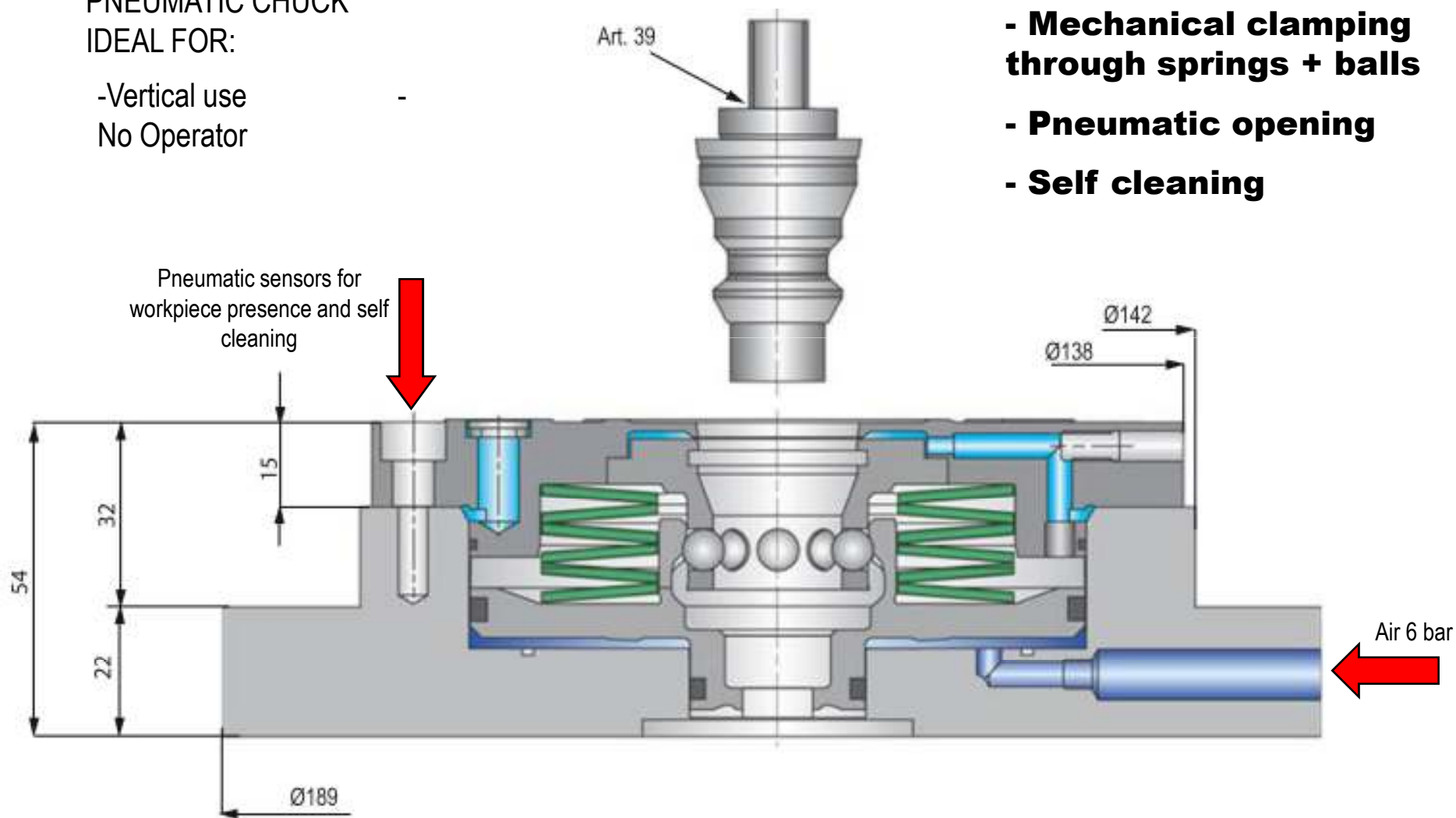

## HYDRAULIC CHUCK

IDEAL FOR:

- Horizontal use
- Operator

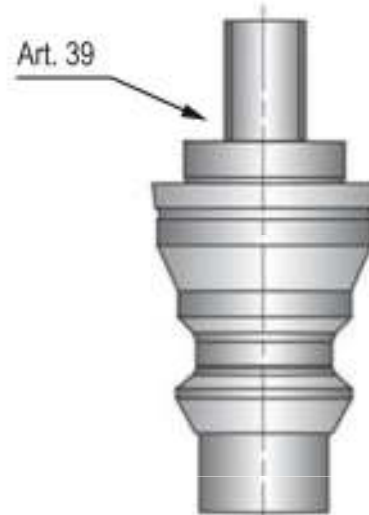

- **Mechanical clamping through springs + balls**
- **Hydraulic opening**
- **No self cleaning**

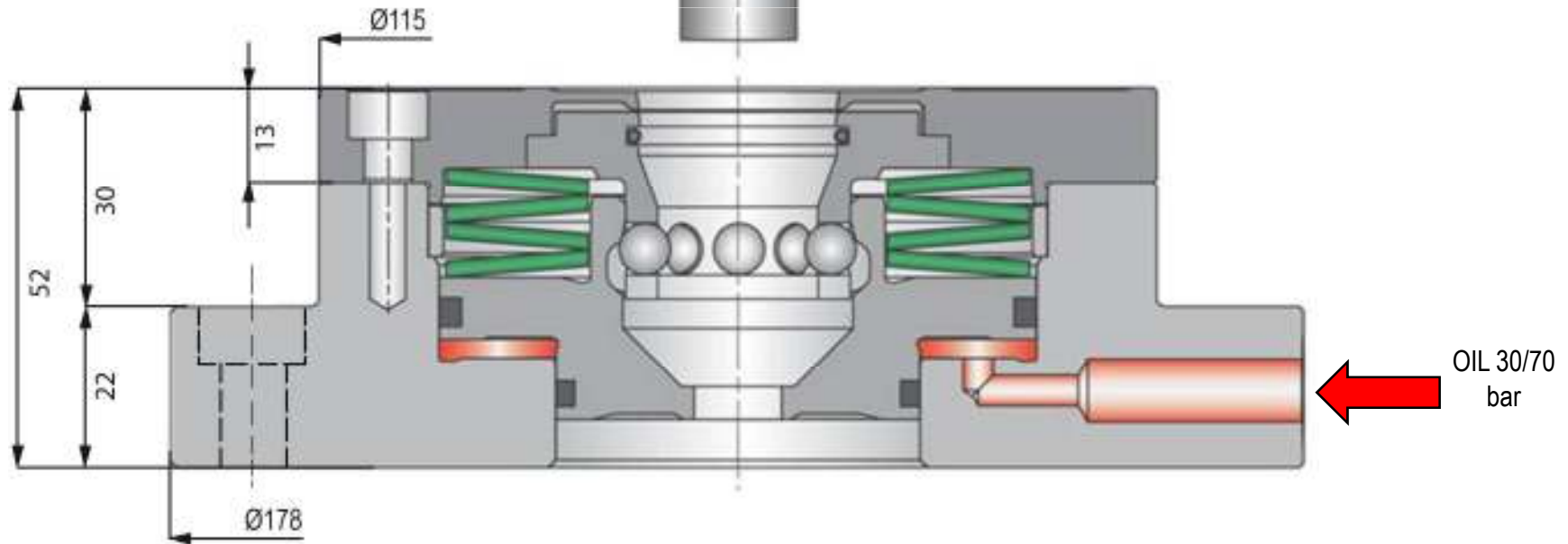

## HYDRAULIC CHUCK

IDEAL FOR:

- Horizontal use
- No Operator

Art. 39



- **Mechanical clamping through springs + balls**
- **Hydraulic opening**
- **Self cleaning**

Pneumatic sensors for workpiece presence and self cleaning

